

Model 6424 Projected Beam Smoke Detector



Models Available

6424 Projected Beam Smoke Detector, includes Transmitter and Receiver

6424A Projected Beam Smoke Detector, ULC listed



Product Overview

30' to 330' protection range

Broad operating temperature range (-22°F to 131°F)

4-wire 24 VDC operation

Receiver and transmitter may be powered separately or together

One EOL power relay supervises both receiver and transmitter

Calibrated test filter included

Ceiling and wall mount brackets included

Alignment LEDs – No special tools required

Built-in automatic gain control compensates for signal deterioration from dust build-up

Remote test station option

3-year warranty

System Sensor Model 6424 Projected Beam Smoke Detector is uniquely suited for protecting open areas with high ceilings where conventional spot type smoke detectors are difficult to install and maintain. Listed for operation at the broadest temperature range in the industry (-22°F to 131°F), the 6424 can be used in garage or warehouse applications to provide early warning in environments where temperature extremes exceed the capability of spot-type smoke detectors.

The 6424 consists of a transmitter and receiver with separate alarm and trouble signals which distinguish between a percentage of signal blockage and a total beam block. Four alignment LEDs on the front of each unit indicate signal strength to ease alignment. The Remote Test Station with alarm LED indicator, Model RTS451, is an accessory that mounts to a standard single gang box and can test and reset the Beam Detector from a remote location.



Engineering Specifications

The projected beam type smoke detector shall be a 4-wire 24 VDC device to be used with U.L. listed separately supplied 4-wire control panels only. Unit shall be listed to U.L. 268 and shall consist of a separate transmitter and receiver capable of being powered separately or together. The detector shall operate in either a short range (30–100 ft.) or long range (100–330 ft.) mode. The temperature range of the beam shall be –22°F to 131°F. The detector shall feature a bank of four alignment LEDs on both the receiver and transmitter that are used to ensure proper alignment of the unit without special tools. The beam detector shall feature automatic gain control which will compensate for gradual signal deterioration from dirt accumulation on lenses. The unit shall include both ceiling and wall mounting brackets. Testing shall be carried out using calibrated test filters or a magnet activated remote test station.

Operational Specifications

Range

30' to 330' (length)
9.1m to 100.9m

Sensitivity

30% ±5% total obscuration, or
55% ±5% total obscuration

Fault Condition (Trouble)

95% or more obscuration,
Automatic gain control limit,
Improper initial alignment

Alignment Aid

Integral signal strength indication
(4 red LEDs)

Alarm Indicator

Local red LED

Trouble Indicator

Local amber LED

Normal Indicator

Local flashing green LED

Test/Reset Features

Obscuration filter
Local reset switch
Remote test and reset switch
capability (compatible with
RTS451 and RTS451KEY test station)

Smoke Detector Spacing

On smooth ceilings, 60 feet between
projected beams and not more
than one-half that spacing between
a projected beam and a sidewall.
Other spacing may be used depending
on ceiling height, airflow characteristics,
and response requirements. See
NFPA 72

Relays

Alarm, trouble
EOL relay is required to supervise power

Environmental Specifications

Temperature

–22°F to 131°F (–30°C to 55°C)

Humidity

10-93% RH noncondensing

Electrical (Receiver) Specifications

Voltage

20 to 32 VDC Maximum

Maximum Ripple Voltage

6.0v (peak to peak)

Standby Current (24 VDC)

10mA maximum

Alarm Current (24 VDC)

28.4mA maximum

Trouble Current (24 VDC)

27.1mA maximum

Start-up Surge Current (24 VDC)

19mA maximum

Relay Contacts Current (24 VDC)

.5A at 30VAC/DC

Reset Time

.6 seconds maximum

Start-up Time (after 5 min. reset)

1 minute maximum

Power Loss

Retain memory for 5 minutes minimum

Electrical (Transmitter) Specifications

Voltage

18.8 to 32 VDC

Maximum Ripple Voltage:

5.6v (peak to peak)

Current (24VDC)

10mA maximum

Mechanical Specifications

Dimensions w/no bracket

2.5"H x 8.5"W x 7"D

Dimensions w/ceiling mount bracket

5.5"H x 8.5"W x 7"D

Dimensions w/wall mount bracket

5.5"H x 8.5"W x 10"D

Weight

Receiver 1.5 lb (663 g)
Transmitter 1.3 lb (598 g)

Mounting

Separate ceiling and wall brackets

Wiring

Plug with attached cable

Beam Smoke Detector Wiring Diagram

Transmitter and Receiver Powered Together

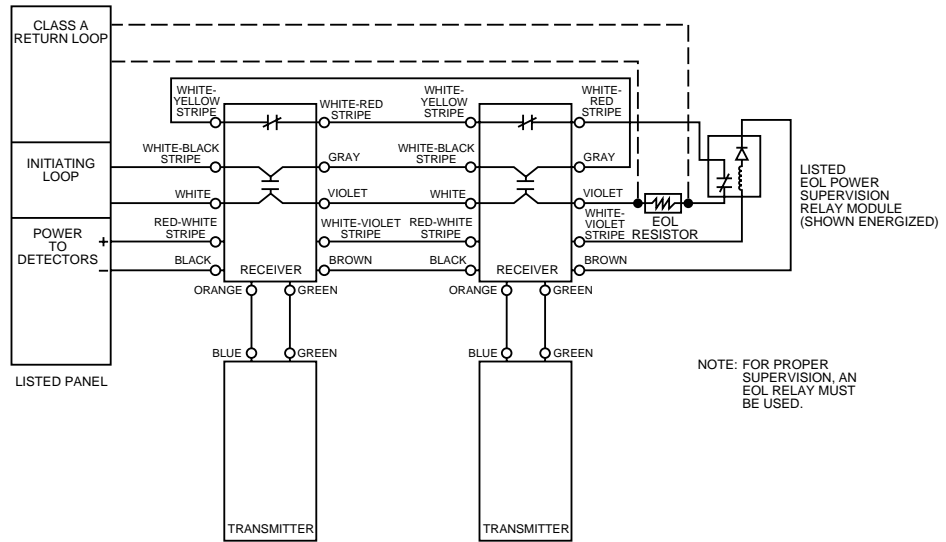

Transmitter and Receiver Powered Separately

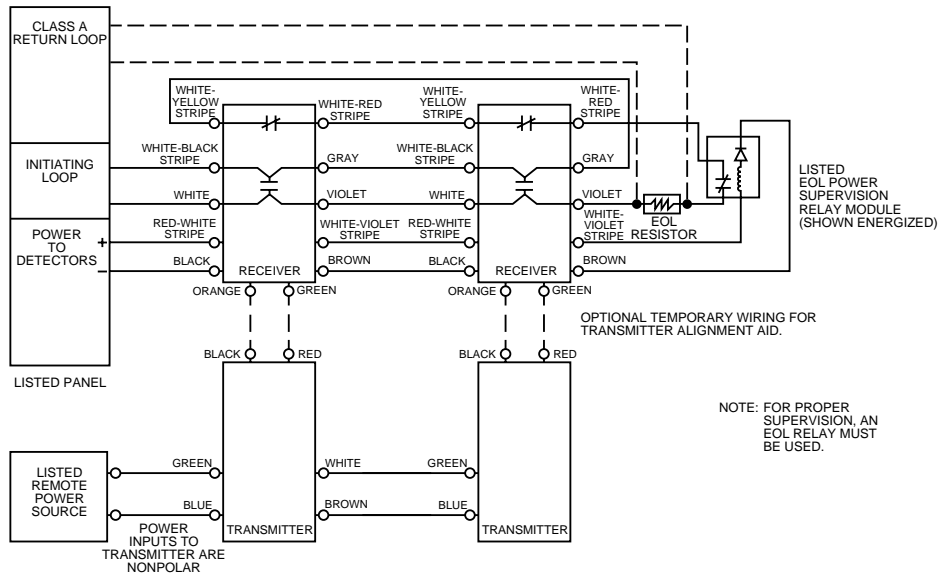

6424 Remote Outputs

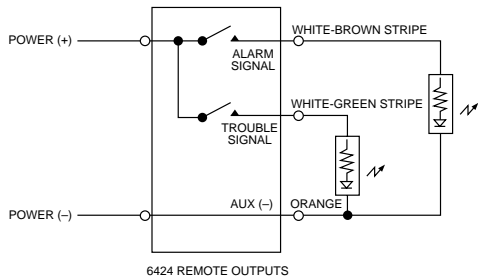

Remote Test Station Connection

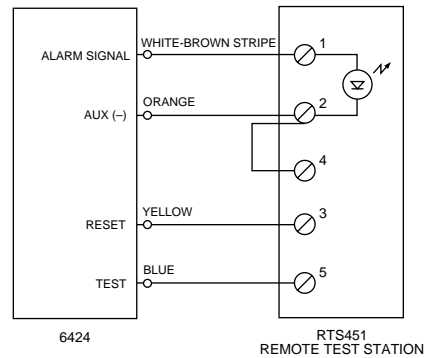

Beam Smoke Detector Mounting Diagrams

Wall Mounting

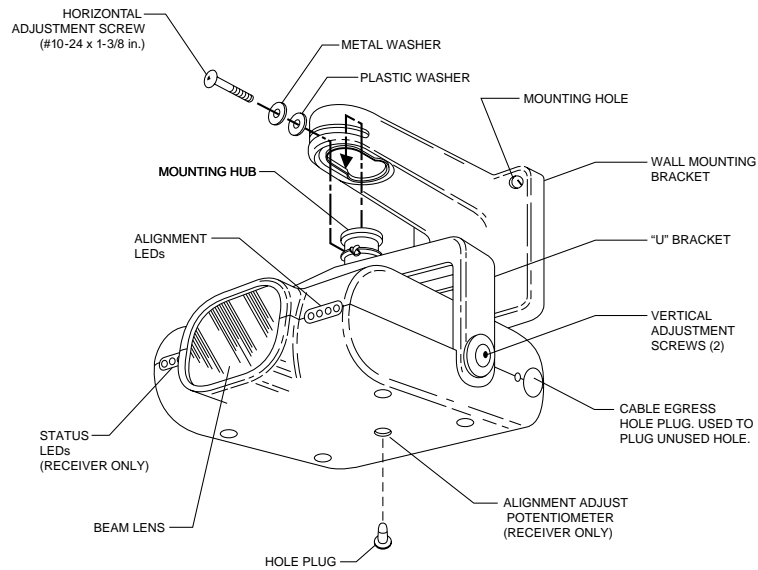

Ceiling Mounting

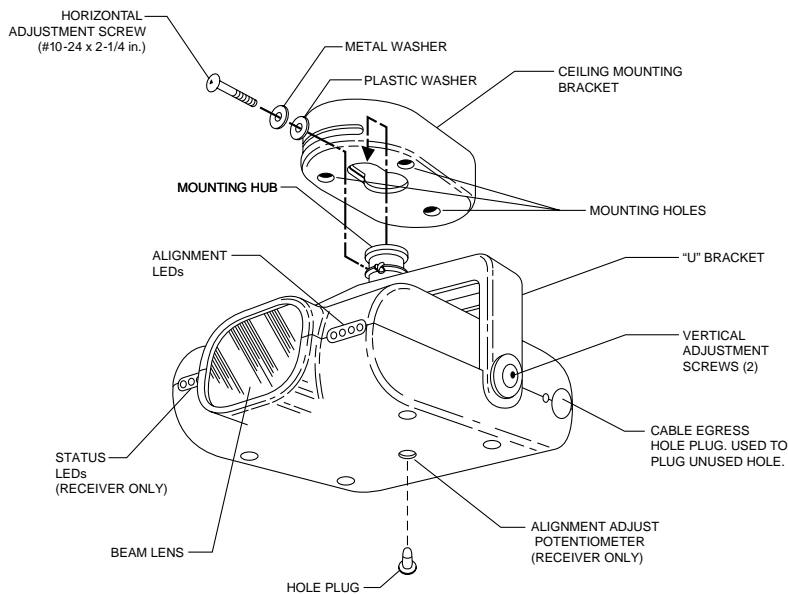

Ordering Information

Part No.	Description
6424	4-Wire, 24 VDC projected beam smoke detector (transmitter, receiver, ceiling and wall mounting brackets)
6424A	Same as above, Canadian model
F37-01-00	Replacement test filter
RTS451	Remote test station
RTS451KEY	Remote test station with key lock
RA400Z	Remote annunciator
A77-716B	End of line relay, 24 VDC
BMB	Conduit kit for ULC model

System Sensor Sales and Service

System Sensor Headquarters
 3825 Ohio Avenue
 St. Charles, IL 60174
 Ph: 800-SENSOR2
 Fx: 630/377-6495
 Documents on Demand
 1-800-736-7672 x3
 www.systemsensor.com

System Sensor Canada
 Ph: 905.812.0767
 Fx: 905.812.0771

System Sensor Europe
 Ph: 44.1403.276500
 Fx: 44.1403.276501

System Sensor in China
 Ph: 86.29.524.6253
 Fx: 86.29.524.6259

System Sensor in Singapore
 Ph: 65.6273.2230
 Fx: 65.6273.2610

System Sensor – Far East
 Ph: 85.22.191.9003
 Fx: 85.22.736.6580

System Sensor – Australia
 Ph: 613.54.281.142
 Fx: 613.54.281.172

System Sensor – India
 Ph: 91.124.6371770
 Fx: 91.124.6373118