

# OSY2 Supervisory Switch



**Models Available**

- OSY2 **OS&Y Supervisory Switch**
- OSY2A **OS&Y Supervisory Switch (ULC/Canadian)**

**Replacement Parts**

- OSYRK Replacement Hardware Kit
- 546-7000 Cover Tamper Switch Kit
- S07-66-xx Tamper Screws for Cover
- WFDW Cover Wrench
- HEXW Replacement Hex Wrench



**Product Overview**

**NEMA 3R rated enclosure**

**User-friendly mounting bracket fits newer valve yokes**

**Single side conduit entry does not require right angle fittings**

**Adjustable length actuator eliminates the need for cutting the shaft**

**Accommodates up to 12 AWG wire**

**Three position switch monitors vandal and valve close signals**

**Two SPDT contacts are enclosed in a durable terminal block for added strength**

**100% synchronization activates both alarm panel and local bell simultaneously**

**System Sensor's OSY2 is used to monitor the open position of an Outside Screw and Yoke (OS&Y) type gate valve.**

**Robust Construction.** The OSY2 consists of a rugged housing, intended for indoor and outdoor use. When installed with the actuator in the vertical position, the OSY2 is NEMA 3R rated per UL.

**Application Flexibility.** The OSY2 features a user-friendly mounting bracket and adjustable shaft to permit mounting to most OS&Y valves, ranging in size from 1" to 12". Its right angle design and wide bracket span provides maximum clearance for valve components, to accommodate troublesome valves. Removing the OSY2's gate valve bracket allows the unit to monitor side-bracket style pressure reducing valves.

**Simplified Operation.** Installation is made easier with the OSY2's single side conduit entrance. By providing a direct conduit pathway to the electrical source, right angle fittings are not required. Installation is further simplified by the OSY2's adjustable length actuator, which eliminates the need for cutting the shaft.

**Reliable Performance.** The OSY2 is equipped with tamper resistant cover screws to prevent unauthorized entry. Inside, two sets of SPDT (Form C) synchronized switches are enclosed in a durable terminal block to assure reliable performance.



S739



CS169



7770-1209:217



OW6A8.AY



167-93-E

## Engineering Specifications

Model shall be model number OSY2 supervisory switch as manufactured by System Sensor. OSY2 shall be installed on each valve as designated on the drawings and/or as specified herein. Switches shall be mounted so as not to interfere with the normal operation of the valve and shall be adjusted to operate within two revolutions of the valve control or when the stem has moved no more than one-fifth of the distance from its normal position. The mechanism shall be contained in a weatherproof die cast metal housing, which shall provide a side entrance for 1/2" conduit and incorporate the necessary facilities for attachment to the valve. A grounding provision is provided. The switch assembly shall include two switches each with a rated capacity of 10 Amp @ 125/250VAC and 2.5 Amp @ 24VDC. The cover shall contain tamper-resistant screws for which a security wrench will be provided with each switch. The OSY2 shall be Underwriters Laboratories listed for indoor or outdoor use. The OSY2 shall be Factory Mutual, CSFM, and MEA approved.

### Standard Specifications

#### Contact Ratings

Two sets of SPDT (Form C)  
10.0 A @ 125/250VAC  
2.5 @ 6/12/24VDC

#### Overall Switch Dimensions

5 3/4"H x 3 1/2"W x 3 1/4"D  
(14.6cm x 8.9cm x 8.2cm)

#### Bracket Span

2 1/4"H x 6 3/4"W x 1"D  
(5.7cm x 17.1cm x 2.5cm)

#### Maximum Stem Extension

2 5/8" (6.7cm)

#### Shipping Weight

2.8 lbs. (1.3 kg)

#### Conduit Entrances

One single side open for 1/2" conduit

#### Operating Temperature Range

32°F to 120°F ( 0°C to 49°C)

NOTE: The OSY2 will operate from -40°F to 120°F (-40°C to 49°C); however UL does not test control valve supervisory switches below 32°F (0°C).

#### Enclosure Rating

UL indoor/outdoor  
NEMA 3R when mounted with the actuator vertical

#### Cover Tamper Switch

Standard with ULC model  
Optional for UL model, part no. 546-7000

#### Service Use

Automatic Sprinkler: NFPA 13  
One or Two Family Dwelling: NFPA 13D  
Residential Occupancies up to 4 stories: NFPA 13R  
National Fire Alarm code: NFPA 72

#### Warranty

3 years

#### U.S. Patent Nos.

5,478,038; 5,213,205

### OSY2 Mounting

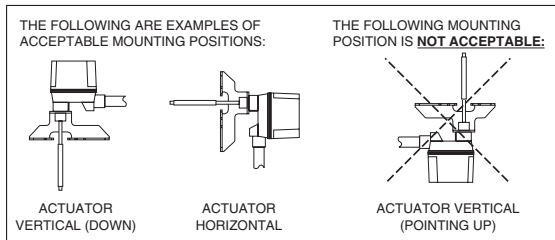

W0211-00

### Electrical Connections for OSY2

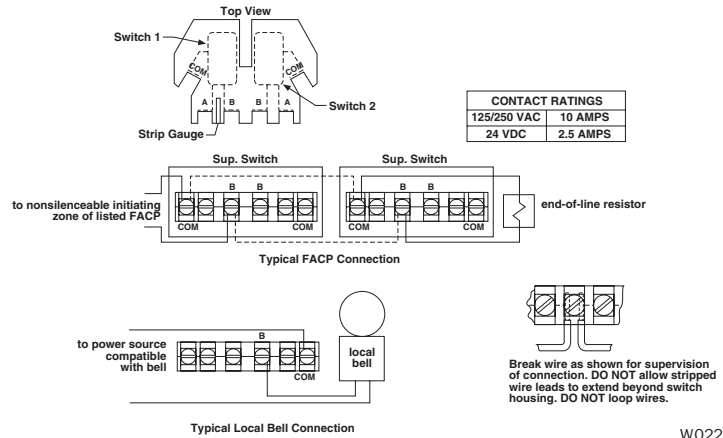

### Ordering Information

Model Number	Description
OSY2	Outside Screw and Yoke valve supervisory switch
OSY2A	Outside Screw and Yoke valve supervisory switch (ULC model)
Part Number	Description
OSYRK	Replacement hardware kit (wrenches, screw pack and J-hooks)
546-7000	Cover tamper switch kit
S07-66-XX	Tamper screws for cover
WFDW	Replacement tamper proof wrench for cover
HEXW	Replacement hex wrench

### System Sensor Sales and Service

#### System Sensor Headquarters

3825 Ohio Avenue  
St. Charles, IL 60174  
Ph: 800/SENSOR2  
Fx: 630/377-6495  
www.systemsensor.com

#### System Sensor Canada

Ph: 905.812.0767  
Fx: 905.812.0771

#### System Sensor Europe

Ph: 44.1403.276500  
Fx: 44.1403.276501

#### System Sensor in China

Ph: 86.29.8832.0119  
Fx: 86.29.8832.5110

#### System Sensor in Singapore

Ph: 65.6273.2230  
Fx: 65.6273.2610

#### System Sensor - Far East

Ph: 85.22.191.9003  
Fx: 85.22.736.6580

#### System Sensor - Australia

Ph: 613.54.281.142  
Fx: 613.54.281.172

#### System Sensor - India

Ph: 91.124.637.1770 x.2700  
Fx: 91.124.637.3118

#### System Sensor - Russia

Ph: 70.95.937.7982  
Fx: 70.95.937.7983